

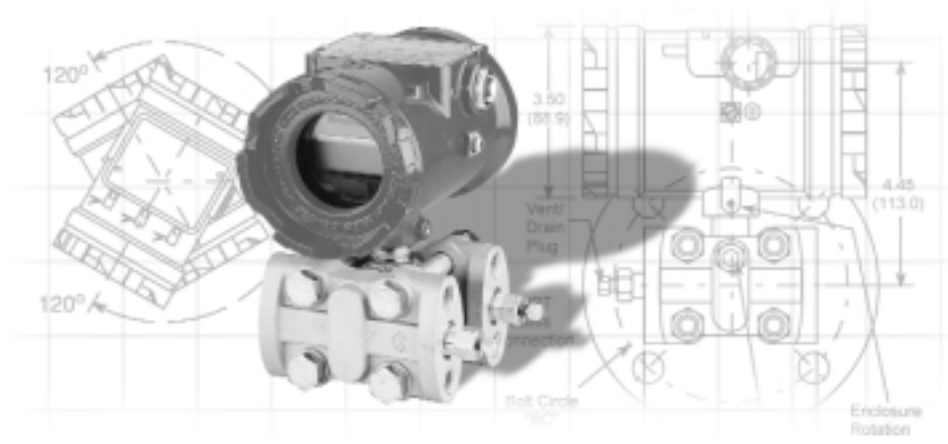

Precision Measurement and Specialty Sensor Technology



Critical Transmitter

Contact → **Information**

MycroSENSOR Technologies
2362 West Shangri La Road
Phoenix, AZ 85029
U.S.A.

Toll Free: 1.866.369.9086
www.mycrosensor.com
email: info@mycrosensor.com

One of less than thirty products accepted for the ISA/Expo98 Innovator's Center, the XTC Critical Transmitter was the first pressure transmitter certified for critical processes by Germany's TÜV organization. TÜV is the only international agency to rate equipment for the amount of safety risk reduction required by a particular application.

The Critical Transmitter achieved such a distinction with built-in hardware and software redundancy. These features ensure fail-safe operation and require a single Critical Transmitter to be installed where two conventional transmitters are usually installed in a critical application (or two critical instead of three conventional), which reduced installation and maintenance costs.

Moreover, the XTC Critical Transmitter seamlessly integrates with DCS and Safety Systems, thereby enhancing the system's ability to deliver a high safety and availability plant solution.

MycroSENSOR XTC® 345 Critical Transmitter

FEATURES & BENEFITS

- ▶ Only certified Critical Transmitter provides unmatched capability at the lowest risk
- ▶ TÜV and other hazardous location certifications accommodate installation in high availability and safety pressure measurement applications
- ▶ Hardware and software redundancy (shown below) reduce overall costs by allowing a single Critical Transmitter to be installed where two conventional transmitters are usually installed or two Critical instead of three conventional
- ▶ Comprehensive self-checking system and primary and secondary current sources (shown below) ensure accurate and safe fault indication
- ▶ Silicon-based MycroSENSOR™ provides exceptional performance
- ▶ Complete loop integrity via output checking and verification provide increased system availability
- ▶ Rotatable NEMA 4X/6P, IP66/68 housing and rotatable display (shown on the next page) delivers long, trouble-free operation and maximum flexibility in mounting options
- ▶ SmartDisplay™ in engineering units affords greater operator understanding



DESCRIPTION

The MycroSENSOR XTC Critical Transmitter is the first TUV-certified pressure transmitter for high availability and safety applications. It achieves this unique distinction via hardware and software redundancy, a comprehensive self-checking system, and primary and secondary current sources to ensure safe fault indication if a failure occurs. These features **allow a single Critical Transmitter to be installed where two conventional transmitters are usually installed in a critical application** (or two Critical instead of three conventional). Thus, the XTC Critical Transmitter minimizes total cost ownership via reduced installation and maintenance expenses.

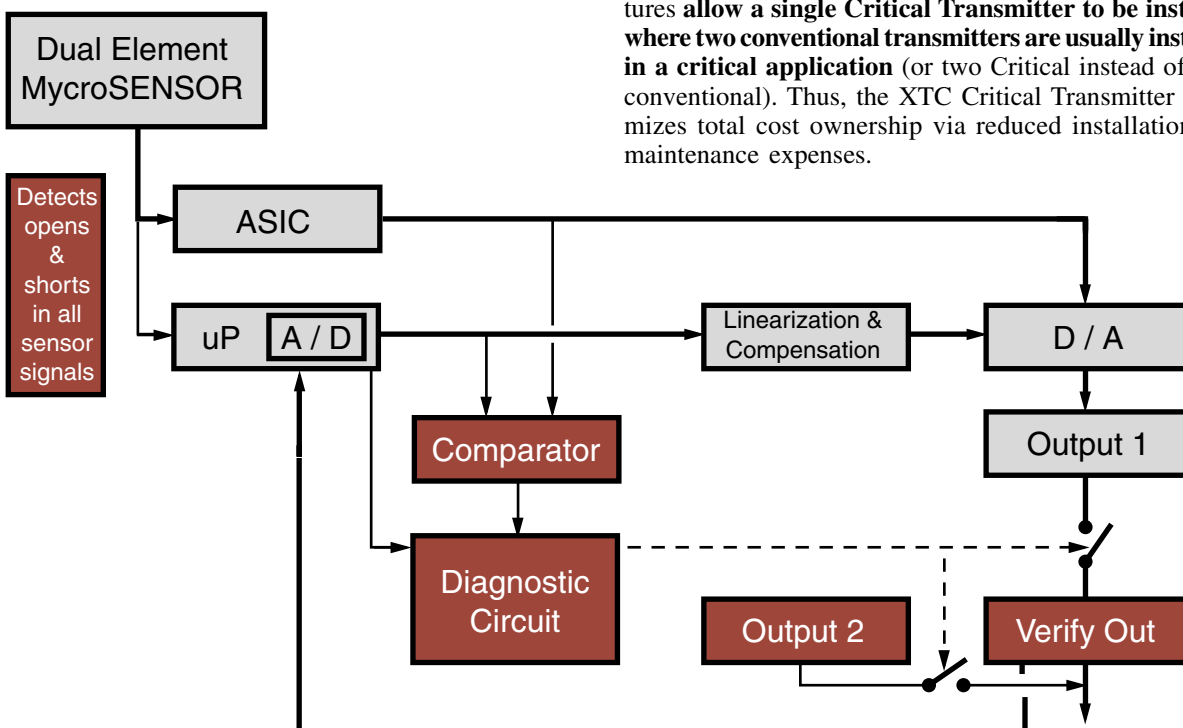

The transmitter carries all standard hazardous location XTC certifications, plus **functional safety approval from Germany's TÜV organization**. TÜV is the only international agency that approves safety systems and instrumentation design for avoidance and control of errors, faults, and human mistakes. It rates equipment for requirement class levels (AKs) to specify the amount of safety risk reduction required by a particular application. TÜV AK levels range from a 0 (no safety provisions required) to an 8 (most dangerous processes); these are roughly parallel to ISA S84.01 safety integrity levels (SILs) 1-4. TÜV AK levels compare to S84's SIL levels as follows:

- ▶ AK 1-3 to SIL 1
- ▶ AK 4 to SIL 2
- ▶ AK 5-6 to SIL 3
- ▶ AK 7-8 to SIL 4

A single Critical Transmitter is approved to AK4, and two working in parallel are approved to AK6, making the Critical Transmitter **the only TÜV approved pressure transmitter on the market today**.

As shown on the previous page, separate processors verify the output of a dual element silicon sensor and use two diverse floating point routines to compute the transmitter output level. If the computed output levels differ, the transmitter output is fixed at a fail-safe level. The output is also fixed at the fail-safe level if the processor detects a difference in the actual output current as compared to the computed current. **This architecture is unique to the XTC Critical Transmitter.**

Moreover, the XTC Critical Transmitter follows techniques proven in the XTC family of transmitters (shown below). These features include the silicon-based dual element capacitive pressure MycroSENSOR featuring a sense and reference capacitor, which is mounted in the XTC's hermetically sealed pressure capsule. As such, the Critical Transmitter delivers high performance and stability with superior reliability and minimal maintenance.

Unique Features of the XTC

Rotatable Smart Display

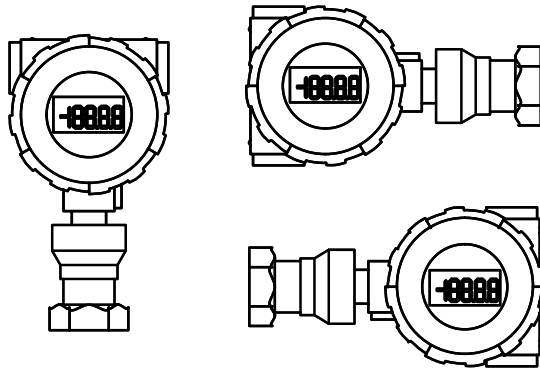

Fully Interchangeable Components

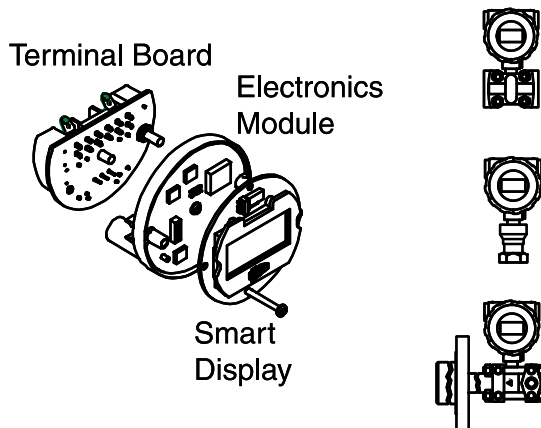

Rotatable NEMA 4X Enclosure

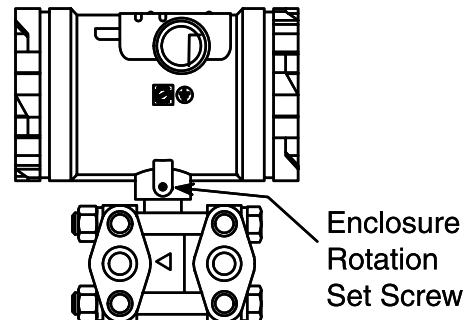
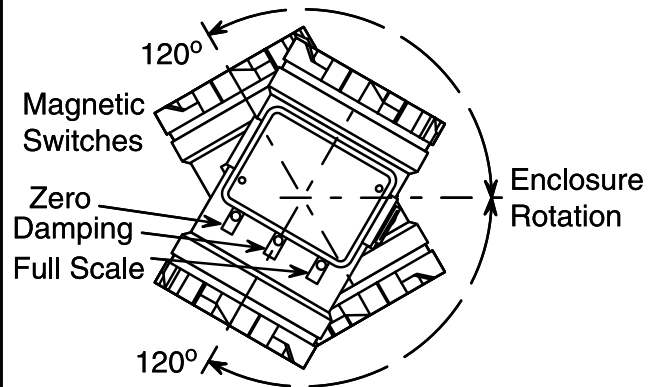

PROCESS CONNECTIONS

**Model 345 Transmitter
with Tantalum Diaphragms**

- ▶ Available in DP, GP, and AP configurations
- ▶ Use in harsh process fluids

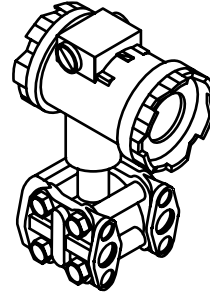

**Model 345 Transmitter
with Remote Diaphragm Seals**

- ▶ Available in various materials and process connections including threaded, flanged, weld-in, and sanitary

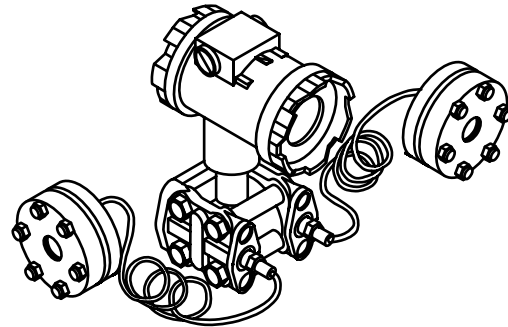

**Model 345D Differential Pressure Transmitter
with Integral Orifice Assemblies**

- ▶ Six integral orifice sizes
- ▶ 316 SS construction
- ▶ 1/2" NPTF process connection
- ▶ "Wet" calibrations available
- ▶ Use in low-flow applications

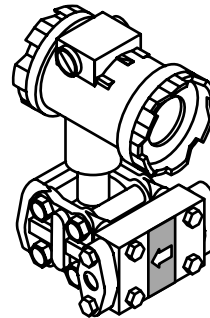

**Model 345D Differential Pressure Transmitter
with Integral 3-Valve Manifold**

- ▶ Factory mounted
- ▶ 316SS or CS construction

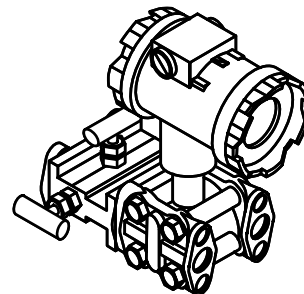

PROCESS CONNECTIONS

**Model 345 Transmitter
with Tantalum Diaphragms**

- ▶ Available in DP, GP, and AP configurations
- ▶ Use in harsh process fluids

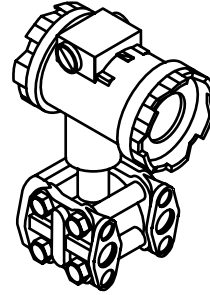

**Model 345 Transmitter
with Remote Diaphragm Seals**

- ▶ Available in various materials and process connections including threaded, flanged, weld-in, and sanitary

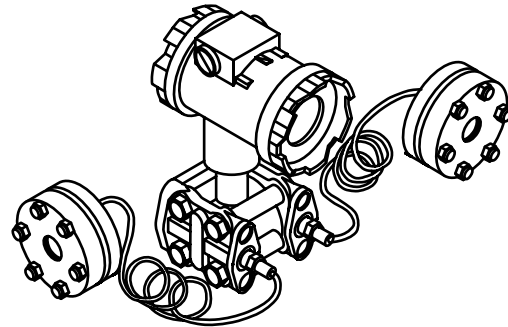

**Model 345D Differential Pressure Transmitter
with Integral Orifice Assemblies**

- ▶ Six integral orifice sizes
- ▶ 316 SS construction
- ▶ 1/2" NPTF process connection
- ▶ "Wet" calibrations available
- ▶ Use in low-flow applications

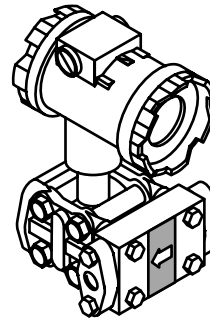

**Model 345D Differential Pressure Transmitter
with Integral 3-Valve Manifold**

- ▶ Factory mounted
- ▶ 316SS or CS construction

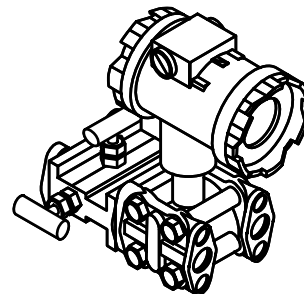

SPECIFICATIONS

PERFORMANCE SPECIFICATIONS

Reference conditions: Zero-based, positive spans, ambient temperature 23°C, D/A trim values equal to span end points, Silicone fill, standard diaphragms, 1 second damping.

Accuracy^{1,2}

Analog Output

Range A:

- ±0.1% of calibrated span for spans from 1:1 to 2:1 of URL
- ±(0.074 + 0.013[URL/Span]) % of calibrated span for spans from 2:1 to 25:1 of URL

Range B:

- ± 0.075% of calibrated span for spans from 1:1 to 2.5:1 of URL
- ± (0.043 + 0.0128 [URL/span]) % of calibrated span for spans from 2.5:1 to 20:1 of URL

Range D, F, G:

- ±0.075% of calibrated span for spans from 1:1 to 10:1 of URL
- ±(0.028 + 0.0047 [URL/span]) % calibrated span for spans from 10:1 to 45:1 of URL

Digital Output

Range A:

- ± 0.0875% of calibrated span for spans from 1:1 to 2:1 of URL
- ± (0.0615 + 0.013[URL/Span]) % of calibrated span for spans from 2:1 to 25:1 of URL

Range B:

- ± 0.0625% of calibrated span for spans from 1:1 to 2.5:1 of URL
- ± (0.0305 + 0.0128 [URL/span]) % of calibrated span for spans from 2.5:1 to 20:1 of URL

Range D,F,G:

- ± 0.0625% of calibrated span for spans from 1:1 to 10:1 of URL
- ± (0.0155 + 0.0047 [URL/span]) % calibrated span for spans from 10:1 to 45:1 of URL

Ambient Temperature Effect

Models 345A, 345G, 345D

Ranges A-B:

- ±(0.175% URL + 0.075% span) per 28°C (50°F)

Ranges D-G:

- ±(0.075% URL + 0.075% span) per 28°C (50°F)

Model 345F

Ranges D-F²:

- ±(0.075% URL + 0.075% span + 1.5 %H₂O) per 28°C (50°F)

Temperature Limits

Sensor Assembly³:

- Silicon: -40 to 125°C (-40 to 257°F)
- Inert Fill: 0 to 85°C (32 to 185°F)
- Paratherm: -20 to 125°C (-4 to 257°F)
- Electronics: -40 to 85°C (-40 to 185°F)

Stability

Zero Stability:

- Ranges A: ±0.1% of URL for 12 months
- Ranges B-G: ±0.03% of URL for 36 months
- Span Stability: No Measurable Span Drift

Humidity

0-100% relative humidity, non-condensing

Vibration Effect

Less than ±0.05% of maximum span per G for 0 to 60 Hz in any axis up to 2 Gs max.

Power Supply Effect

Less than 0.005% of output span per volt

EMI/RFI Susceptibility

Less than 0.25% of max. span at 30 V/m, 30 MHz - 1 GHz

ESD Susceptibility

IEC severity level 4, 15 kV

Static Pressure Effect (340D)

Range Span Error Correctable To:⁴

- B 0.2% per 100psi
- D 0.2% per 1000psi
- F 0.2% per 1000psi

NOTES:

- (1) Accuracy includes the effects of linearity, hysteresis and repeatability.
- (2) Specifications for 3" & 4" flange size only. For smaller flange sizes, consult MycroSENSOR Technologies.
- (3) Limit to 85°C (185°F) in vacuum service.
- (4) Zero effect eliminated at operating pressure.

Specifications are subject to change without notice.

FUNCTIONAL SPECIFICATIONS

Range and Sensor Limits Model 345A, 345D, 345F, 345G

Range	Min. Span	LRL/URL			
		345A	345D	345F	345G
A	0.20" (.05KPA)	NA	-2/5" (5/1.25KPA)	NA	NA
B	0.75" (0.185KPA)	NA	-15/15" (-3.7/3.7KPA)	NA	NA
D	10" (2.5KPA)	0/450" (0/112.5KPAabs)	-450/450" (-112.5/112.5KPA)	-450/450" (-112.5/112.5KPA)	-407/450" (-101/112.5KPA)
F	12.6psi (87KPA)	0/450psia (0/3045KPAabs)	-150/450psi (-689/3100KPA)	-150/450psi (-689/3100KPA)	-14.7/450psig (-101/3100KPA)
G	300psi (2068KPA)	NA	NA	NA	0/5500psig (0/37920KPA)

Zero Elevation and Suppression

The range may be set anywhere between the LRL and URL of the transmitter, so long as the calibrated span meets the minimum allowable span in the table above. Zero and span in the XTC are non-interactive.

Electronic Damping (Digital Filter)

Adjustable between 0 and 30 seconds

Transmitter Outputs

Each transmitter has:

- ▶ Analog, Two-Wire 4-20mA
- ▶ Digital, HART Communications
- ▶ Optional Transient Suppressor

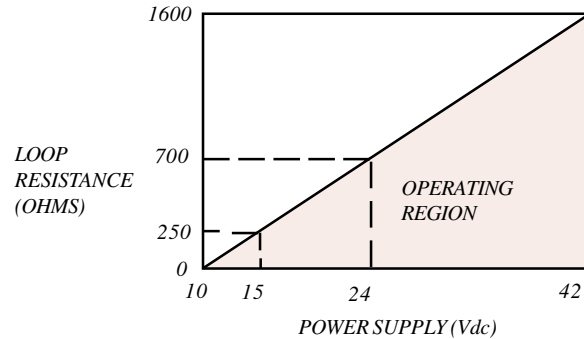

Power Supply Requirements

Minimum Terminal to Terminal Compliance

Voltage: +10 Vdc

Maximum Terminal to Terminal Voltage: +42 Vdc

Maximum Load: RL = 50° (Supply Voltage)

- 500 Ohms¹

Maximum Working Pressure²

Range	345A	345D	345G	345F
A	NA	+/-60 psi ³ (+/-413KPA)	NA	NA
B	NA	+/-100 psi ³ (+/-689KPA)	NA	NA
D	250psi (1.72MPA)	+/-4000 psi (+/-27.6MPA)	250 psi(1.72MPA)	Per Flange
F	1500psi (10.3MPA)	+/-4000 psi (+/-27.6MPA)	1500 psi(10.3MPA)	Per Flange
G	NA	NA	9,000 psi(6SS only 62.0MPA)	NA

NOTES:

(1) To ensure digital communications, HART requires the loop resistance to remain between 250 and 1100 Ohms. HART also imposes the following requirements on the loop power supply:

Ripple: 0.2 Vp-p, 47-125 Hz
Noise: 0.6 mV RMS maximum
Impedance: 10 Ohms maximum

(2) The Maximum Working Pressure (MWP) is defined as the maximum pressure that can be applied to the cell without damage, static, or otherwise.

(3) 345D Range A and Range B sensors have a body rating of +/-4000 psi; however, no over pressure protection is employed in these units, thereby limiting the MWP to +/- 100 psi.

Flange Rating

Standard	Class	Carbon Steel Rating	Stainless Steel Rating
ANSI	150#	285 psi ¹	275 psi ¹
ANSI	300#	740 psi ¹	720 psi ¹
DIN	PN 10/16	16 bar ²	16 bar ²
DIN	PN 25/40	40 bar ²	40 bar ²

Surge Protection (with optional Transient Suppressor)

Maximum clamping voltage (either loop terminal to enclosure)
 DC: 68V
 100 kV per microsecond AC surge: 70V peak
 1000 kV per microsecond AC surge: 120V peak
 Transient surge current
 Up to 5000 amp for 20 microseconds, repeated strikes
 Turn-On Time
 The transmitter will begin operating within 5 seconds after power is applied. The transmitter will perform within specifications within 60 seconds after power is applied.

Local Indication

Optional 4 1/2 Digit SmartDisplay

MECHANICAL SPECIFICATIONS

Dimensions

See Installation Drawings (Pages G15-G17)

Weight³

345A/G:⁴ 4 lbs/1.8 kg
 345D: 7 lbs/3.2 kg
 345F: 20 lbs/9.1 kg

Electronics Housing

Epoxy Powder Coated, Low Copper Cast Aluminum
 316 SS (optional)
 NEMA 4X/6P (IP66/68)
 (2) 1/2" -14 NPTF Electrical Conduit
 Entrances (M20 x 1.5 optional)

Process Wetted Parts

Various Materials Available
 NACE MR0175 compliant with options as noted in the model number breakdown.

Process Connections

Model 345A/G⁵

(1) 1/2" NPTF, no vent/drain (External block and bleed may be purchased separately)

Model 345D

(2) 1/4" NPTF with vent/drains
 (1/2" NPTF with optional process adapters)

Model 345F

High Pressure Side: Per flange size and rating selected

Low Pressure Side: 1/4" NPTF with vent/drain
 (1/2" NPTF with process adapter provided)

Hazardous Area Classification/Approvals⁶

TÜV Approvals (Standard):

Single Transmitter: AK4

Two Transmitters: AK6

European Community Approved

ABS Type approved

FM/CSA Approval:

Intrinsically Safe:

Class I, Div. 1, Groups A, B, C, & D

Class II, Div. 1, Groups E, F, & G

Class III, Div. 1

Explosion Proof:

Class I, Div. 1, Groups B, C, & D

Class II, Div. 1, Groups E, F, & G

Class III, Div. 1

Non-Incendive:

Class I, Div. 2, Groups A, B, C, & D

CENELEC Approval:

Intrinsically Safe: EEx ia IIC T6, T5, T4

Explosion Proof: EEx d [ia] ia, IIC T4⁷

BASEEFA Approval:

Non-Incendive: Exn IIC T6

SAA Approval:

Intrinsically Safe: Ex ia IIC T6

Explosion Proof: Ex d IIB T6

Non-Incendive: Ex n DIP IIC T6

NOTES:

- (1) At 100°F (38°C), the rating decreases with increasing temperature.
- (2) At 120°C, the rating decreases with increasing temperature.
- (3) Weights approximate.
- (4) 345A/G with tantalum diaphragm: 7 lbs.
- (5) 345A/G Transmitters with tantalum diaphragms are differential style units. Process connections are similar to 345D. See drawings.
- (6) Consult MycroSENSOR for information on additional approvals.
- (7) Consult MycroSENSOR for information on special power requirements for EExd models.

MODEL NUMBER

Critical Absolute Pressure

345A Critical Absolute Pressure Transmitter

Input Range: Span Limits, Min/Max

D 10/450" H₂O abs (2.5/112.5 KPA abs)

F 12.6/450 psia (87/3100 KPA abs)

Output

B 4-20 mAdc with HART Protocol¹

C 4-20 mAdc with HART Protocol & Integral Transient Suppressor

D Spare Capsule

Process Diaphragm

H Hastelloy C-276¹

S 316L SS

B Hastelloy C-276 with 1 Remote Seal (Specify AA for Body Parts)

Body Parts

<u>Wetted</u>	<u>Process Connection</u>
AA 316SS	1/2" NPT ¹
BA Hastelloy-C276	1/2" NPT

Fill Fluid

B Silicone DC200¹

C Inert

D Paratherm

Output Indicator

5 4-1/2 Digit Digital SmartDisplay

N Not Required⁵

Standard Options

X Oxygen Cleaned¹⁹

Y Special Features⁴

N Not Required⁵

Mounting Bracket

1 2" Pipe Mount Bracket with SS Hardware

2 Universal Bracket

3 2" Pipe Mount 316SS Bracket

N Not Required⁵

Housing

1 Aluminum 1/2" - 14 NPT¹

2 Aluminum M20 x 1.5¹⁸

3 316 SS 1/2" - 14 NPT

4 316 SS M20 x 1.5¹⁸

N Not Required⁵

Hazardous Area Classification (TÜV Approval Standard)

2 CSA/CRN

3 FM/CSA All¹

M CENELEC EEx d [ia] ia¹³

R SAA All & ABS Type Approved¹³

L CENELEC EExia & BASEEFA TFX N

N Non-Approved⁵

W FM/CSA All & ABS Type Approved

345A F B H AA B 5 N N 1 3 *Sample Model Number*

See notes on page G-13.

Critical Differential Pressure

345D Critical Differential Pressure Transmitter

Input Range: Span Limits, Min/Max

- A 0.2/5 "H₂O (0.05/1.25 KPA)¹⁰ (Remote seals not available with this range.)
- B 0.75/15 "H₂O (0.185/3.7 KPA)² (Matched remote seals only with this range.)
- D 10/450 "H₂O (2.5/112.5 KPA)²
- F 12.6/450 psi (87/3100 KPA)²

Output

- B 4-20 mA_{dc} with HART Protocol^{1,2}
- C 4-20 mA_{dc} with HART Protocol & Integral Transient Suppressor
- D Spare Capsule

Process Diaphragm

- H Hastelloy C-276^{2,3,7,10}
- S 316L SS^{2,6}
- A Hastelloy C-276 with 2 Remote Seals^{9,11}
- B Hastelloy C-276 with 1 Remote Seal on high side^{9,12}
- C Hastelloy C-276 with 1 Remote Seal on low side^{9,12}

Body Parts

	Wetted	Vent/Drain	Process Conn.
AA	316SS	End	1/2 NPT ^{1,2}
AB	316SS	Side (top)	1/2 NPT
AC	316SS	Side (bottom)	1/2 NPT
AD	316SS	Side (dual)	1/2 NPT
AE	316SS	End	1/4 NPT
AF	316SS	Side (top)	1/4 NPT
AG	316SS	Side (bottom)	1/4 NPT
AH	316SS	Side (dual)	1/4 NPT
BA	Hastelloy C-276	End	1/2 NPT
BB	Hastelloy C-276	Side (top)	1/2 NPT
BC	Hastelloy C-276	Side (bottom)	1/2 NPT
BD	Hastelloy C-276	Side (dual)	1/2 NPT
BE	Hastelloy C-276	End	1/4 NPT
BF	Hastelloy C-276	Side (top)	1/4 NPT
BG	Hastelloy C-276	Side (bottom)	1/4 NPT
BH	Hastelloy C-276	Side (dual)	1/4 NPT
RR	Remote Seals		

Fill Fluid

- B Silicone DC200^{1,2}
- C Inert¹¹
- D Paratherm¹¹

Output Indicator

- 5 4-1/2 Digit Digital SmartDisplay²
- N Not Required⁵

Standard Options

- D B7M Bolts³
- E B8M Bolts¹⁶
- X Oxygen Cleaned¹⁹
- Y Special Features⁴
- N Not Required^{2,5}

Mounting Bracket

- 1 2" Pipe Mount Bracket with SS Hardware²
- 2 Universal Bracket
- 3 2" Pipe Mount 316SS Bracket
- N Not Required⁵

Housing

- 1 Aluminum 1/2" - 14 NPT^{1,2}
- 2 Aluminum M20 x 1.5¹⁸
- 3 316 SS 1/2" - 14 NPT
- 4 316 SS M20 x 1.5¹⁸
- N Not Required⁵

Hazardous Area Classification (TÜV Approval Standard)

- 2 CSA/CRN
- 3 FM/CSA All^{1,2}
- M CENELEC EEx d [ia] ia¹³
- R SAA All & ABS Type Approved
- L CENELEC EExia & BASEEFA
- N Non-Approved
- W FM/CSA All & ABS Type Approved

345D D B H AA B 5 N 1 1 3 *Sample Model Number*

See notes on page G-13.

Critical Flanged Level Pressure

345F Critical Flanged Level Pressure Transmitter

Input Range: Span Limits, Min./Max.

D 10/450 "H₂O (2.5/112.5 KPA)²

F 12.6/450 psi (87/3100 KPA)²

Output

B 4-20 mAdc with HART Protocol^{1,2}

C 4-20 mAdc with HART Protocol & Integral Transient Suppressor

Body Parts

	High Side Dia/Wetted	Low Side Dia/Wetted	Extension Length
A0 316SS		Hastelloy C-276/316SS	Flush Mount ^{1,2}
A2 316SS		Hastelloy C-276/316SS	2" ¹⁵
A4 316SS		Hastelloy C-276/316SS	4" ¹⁵
A6 316SS		Hastelloy C-276/316SS	6" ¹⁵
B0 Hastelloy C-276		Hastelloy C-276/316SS	Flush Mount
B2 Hastelloy C-276		Hastelloy C-276/316SS	2" ¹⁵
B4 Hastelloy C-276		Hastelloy C-276/316SS	4" ¹⁵
B6 Hastelloy C-276		Hastelloy C-276/316SS	6" ¹⁵
C0 Monel		Hastelloy C-276/316SS	Flush Mount
C2 Monel		Hastelloy C-276/316SS	2" ¹⁵
C4 Monel		Hastelloy C-276/316SS	4" ¹⁵
C6 Monel		Hastelloy C-276/316SS	6" ¹⁵
D0 Tantalum		Hastelloy C-276/316SS	Flush Mount
G0 316SS		Remote Seal	Flush Mount
G2 316SS		Remote Seal	2" ¹⁵
G4 316SS		Remote Seal	4" ¹⁵
G6 316SS		Remote Seal	6" ¹⁵

Mounting Flange

Size	Rating	Material	Size	Rating	Material	Size	Rating	Material
A 2"	150#	CS	J 3"	150#	SS ¹	S 100mm	10/16 Bar	CS
B 2"	300#	CS	K 3"	300#	SS	T 100mm	25/40 Bar	CS
C 3"	150#	CS ²	L 4"	150#	SS	U ¹⁷ 50mm	10/16 Bar	SS
D 3"	300#	CS	M 4"	300#	SS	V ¹⁷ 50mm	25/40 Bar	SS
E 4"	150#	CS	N ¹⁷ 50mm	10/16 Bar	CS	W 80mm	10/16 Bar	SS
F 4"	300#	CS	P ¹⁷ 50mm	25/40 Bar	CS	X 80mm	25/40 Bar	SS
G* 2"	150#	SS	Q 80mm	10/16 Bar	CS	Y 100mm	10/16 Bar	SS
H* 2"	300#	SS	R 80mm	25/40 Bar	CS	Z 100mm	25/40 Bar	SS

Fill Fluid

	High Side	Low Side
B	Silicone DC200	Silicone DC200 ^{1,2}
C	Fluorolube	Inert
D	NEOBEE	Paratherm
E	Silicone DC550	Silicone DC200
F	Silicone DC704	Silicone DC200
G	Syltherm 800	Silicone DC200

Output Indicator

5 4-1/2 Digit Digital SmartDisplay²

N Not Required

Standard Options

D B7M Bolts³

E B8M Bolts¹⁷

X Oxygen Cleaned¹⁹

Y Special Features⁴

N Not Required²

Mounting Bracket

N Not Required

Housing

1 Aluminum 1/2" - 14 NPT^{1,2}

2 Aluminum M20 x 1.5¹⁸

3 316 SS 1/2" - 14 NPT

4 316 SS M20 x 1.5¹⁸

Hazardous Area Classification (TÜV Approval Standard)

2 CSA/CRN

3 FM/CSA AII^{1,2}

M CENELEC EEx d [ia] ia¹³

R SAA All & ABS Type Approved

L CENELEC EExia & BASEEFA Type N

N Non-Approved

W FM/CSA AII & ABS Type Approved

345FD B A0 C B 5 N N 1 3 *Sample Model Number*

See notes on page G-13.

Critical Gauge Pressure

345G Critical Gauge Pressure Transmitter

Input Range: Span Limits, Min/Max

- D 10/450" H₂O (2.5/112.5 KPA)²
- F 12.6/450 psig (87/3100 KPA)²
- G 300/5500 psig 2008/37920 KPA)²

Output

- B 4-20 mAdc with HART Protocol^{1,2}
- C 4-20 mAdc with HART Protocol & Integral Transient Suppressor
- D Spare Capsule

Process Diaphragm

- H Hastelloy C-276^{1,2,3}
- S 316L SS
- B Hastelloy C-276 with 1 Remote Seal (Specify AA for Body Parts)

Body Parts

	<u>Wetted</u>	<u>Process Connection</u>
AA	316SS	1/2" NPT ^{1,2}
BA	Hastelloy C-276	1/2" NPT

Fill Fluid

- B Silicone DC200^{1,2}
- C Inert
- D Paratherm

Output Indicator

- 5 4-1/2 Digit Digital SmartDisplay²
- N Not Required⁵

Standard Options

- X Oxygen Cleaned¹⁹
- Y Special Features⁴
- N Not Required⁵

Mounting Bracket

- 1 2" Pipe Mount Bracket with SS Hardware²
- 2 Universal Bracket
- 3 2" Pipe Mount 316SS Bracket
- N Not Required⁵

Housing

- 1 Aluminum 1/2" - 14 NPT^{1,2}
- 2 Aluminum M20 x 1.5¹⁸
- 3 316 SS 1/2" - 14 NPT
- 4 316 SS M20 x 1.5¹⁸
- N Not Required⁵

Hazardous Area Classification (TÜV Approval Standard)

- 2 CSA/CRN
- 3 FM/CSA All^{1,2}
- M CENELEC EEx d [ia] ia¹³
- R SAA All & ABS Type Approved
- L CENELEC EExia & BASEEFA
- N Non-Approved⁵
- W FM/CSA All & ABS Type Approved

345G F B H AA B 5 N 1 1 3 *Sample Model Number*

See notes on page G-13.

Tantalum Diaphragms

345 Absolute, Gauge, & Differential Critical Pressure Transmitter with Tantalum Diaphragms

Type and Input Range: Span Limits, Min/Max

Type	Span Limits, Min/Max
DD Differential	10/450 "H ₂ O (2.5/112.5 KPA)
GD Gauge	10/450 "H ₂ O (2.5/112.5 KPA)
GF Gauge	12.6/450 psi (87/3100 KPA)
AD Absolute	10/450 "H ₂ O Abs (2.5/112.5 KPA)
AF Absolute	12.6/450 psia (87/3100 KPA)

Output

B	4-20 mA _{dc} with HART Protocol ¹
C	4-20 mA _{dc} with HART Protocol & Integral Transient Suppressor
D	Direct Connection to Model 348 Field Mounted Controller or Spare Capsule

Diaphragm

T Tantalum

Body Parts

	Hi Side	Lo Side	Use with
TB	Hastelloy-C	316SS	A, G
TC	Hastelloy-C	Hastelloy-C	D
TD	Monel	316SS	A, G ¹
TE	Monel	Monel	D ¹

Fill Fluid

B	Silicone DC200
C	Inert ¹³

Output Indicator

5	4-1/2 Digit Digital SmartDisplay
N	Not Required

Standard Options

D	B7M Bolts ³
E	B8M Bolts ¹⁶
X	Oxygen Cleaned ¹⁹
Y	Special Features ⁴
N	Not Required ⁵

Mounting Bracket

1	2" Pipe Mount Bracket with SS Hardware
2	Universal Bracket
3	2" Pipe Mount 316SS Bracket
N	Not Required ⁵

Housing

1	Aluminum 1/2 - 14 NPT ¹
2	Aluminum M20 x 1.5 ¹⁸
3	316 SS 1/2" - 14 NPT
4	316 SS M20 x 1.5 ¹⁸
N	Not Required ⁵

Hazardous Area Classification (TÜV Approval Standard)

2	CSA/CRN
3	FM/CSA AII ¹
M	CENELEC EEx d [ia] ia ¹³
R	SAA AII & ABS Type Approved
L	CENELEC EExia & BASEEFA
N	Non-Approved
W	FM/CSA AII & ABS Type Approved

345DD B T TE B N N N 1 3 *Sample Model Number*

NOTES:

- (1) Standard for all ranges.
- (2) Stock model selection.
- (3) NACE MR0175 compliance requires this option.
- (4) Please describe the modification or provide a quotation reference number.
- (5) Required selection for OUTPUT option "D", direct connection to the MycroSENSOR 348.
- (6) Standard on Input Ranges A & B.
- (7) Standard on Input Ranges D & F.
- (8) Must specify Body Parts code "RR".
- (9) Must select Body Parts "AA".
- (10) Not available with Input Range "A".
- (11) Not available with Input Range "A" or "B".
- (12) Available with Body Parts "TD" or "TE" only.
- (13) CENELEC EExd & SAA units are only available with OUTPUT code "B".
- (14) 2" flanges with an extension are not available.
- (15) 3" and 4" flanges with an extension will fit into Schedule 80 and larger i.d. pipes.
- (16) B8M (316SS) bolting may have a reduced pressure rating. Consult MycroSENSOR for more information.
- (17) Extended diaphragm not available with these sizes.
- (18) Not available with FM/CSA approvals.
- (19) Oxygen cleaned option requires inert fill fluid.

MODEL DIFFERENCES & MODIFICATIONS

If no range is selected, the instrument will be calibrated as follows:

Range Code	Default Calibration
A	-0.5 to 0.5 "H ₂ O
B	0 to 10 "H ₂ O
D	0 to 100 "H ₂ O (or "H ₂ O abs)
F	0 to 100 PSI (or PSIA)
G	0 to 1000 PSIG

Common modifications can be specified by selecting a Y in the Special Features category and describing the modification. **Always consult your salesperson before ordering a modification.**

TRANSMITTER COMPONENTS

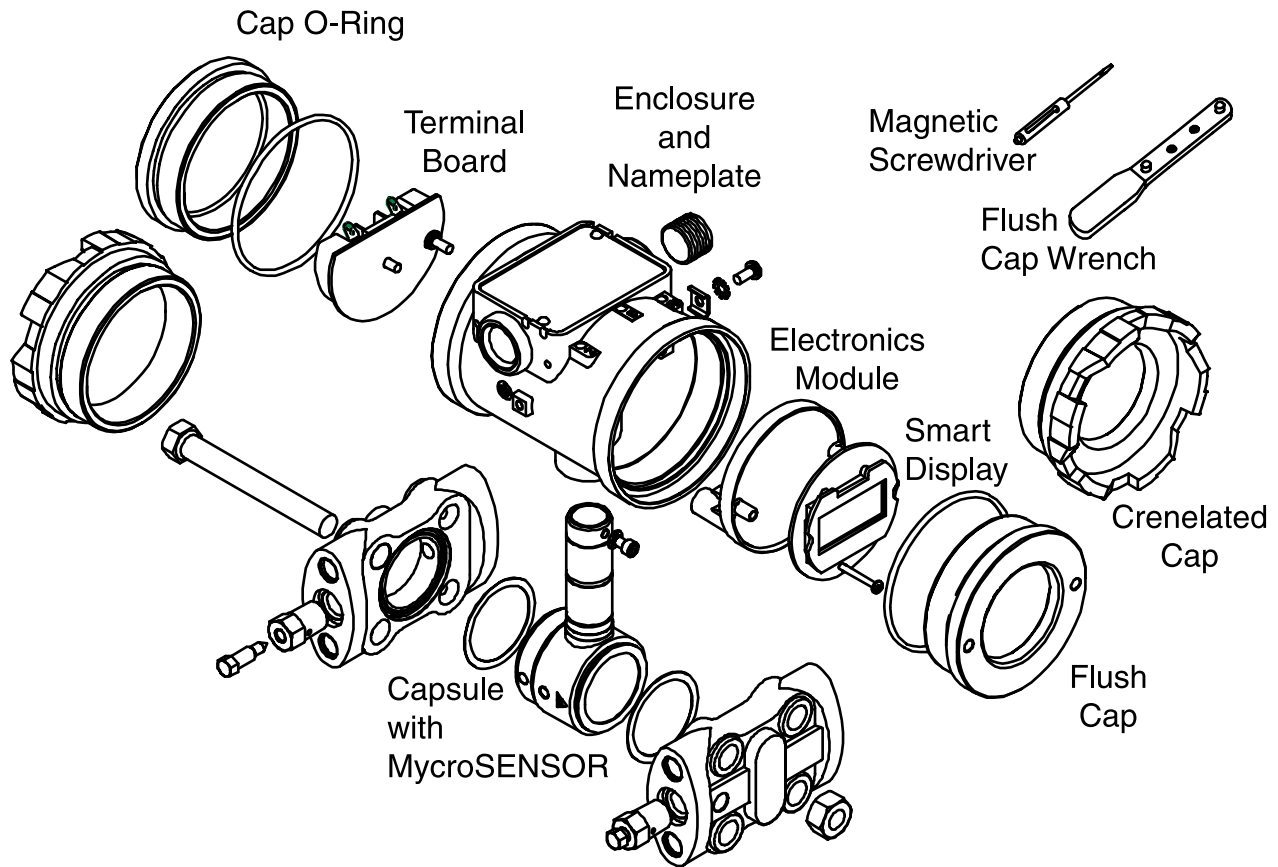

Mount to Bracket
with 7/16"-20 Bolts
and Lockwashers,
4 places

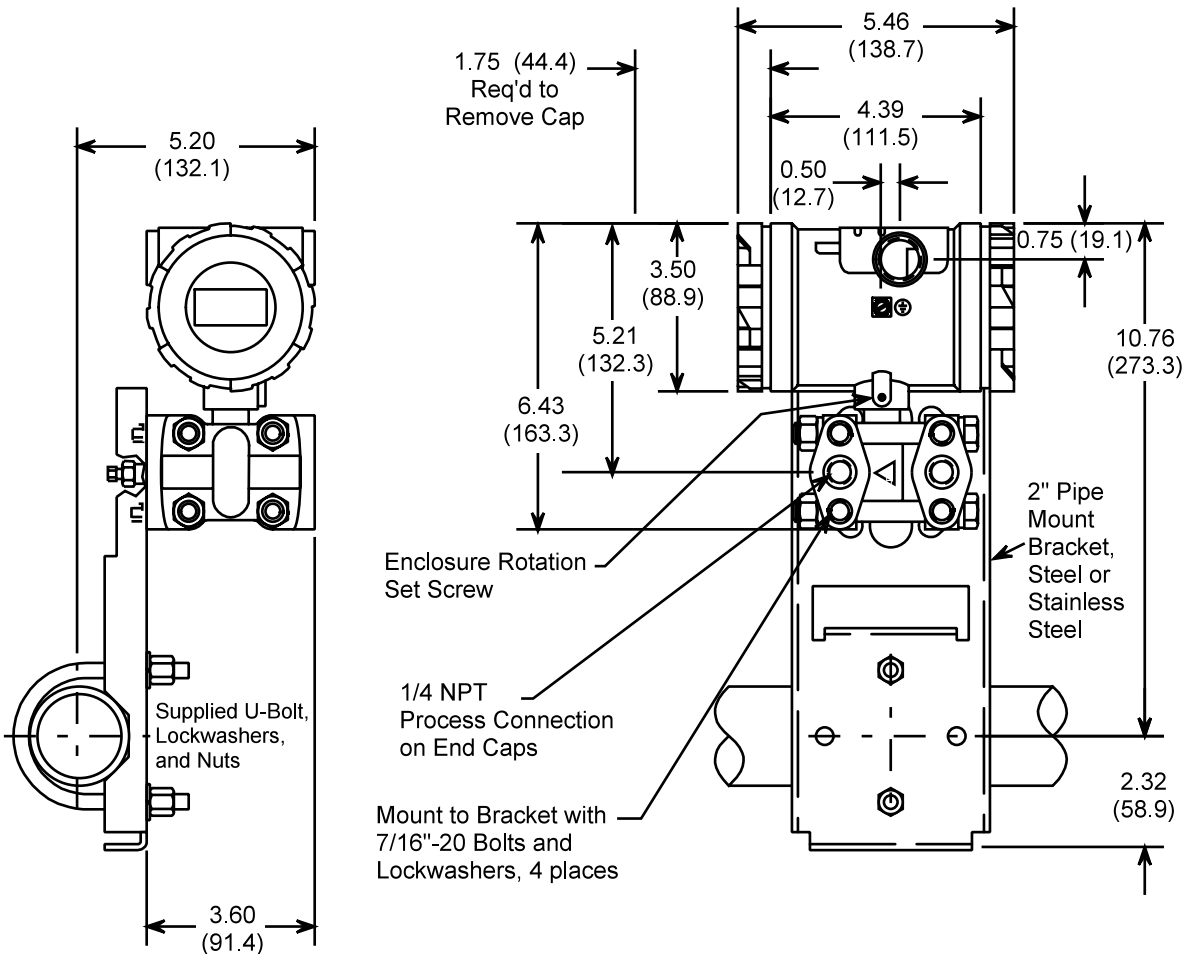
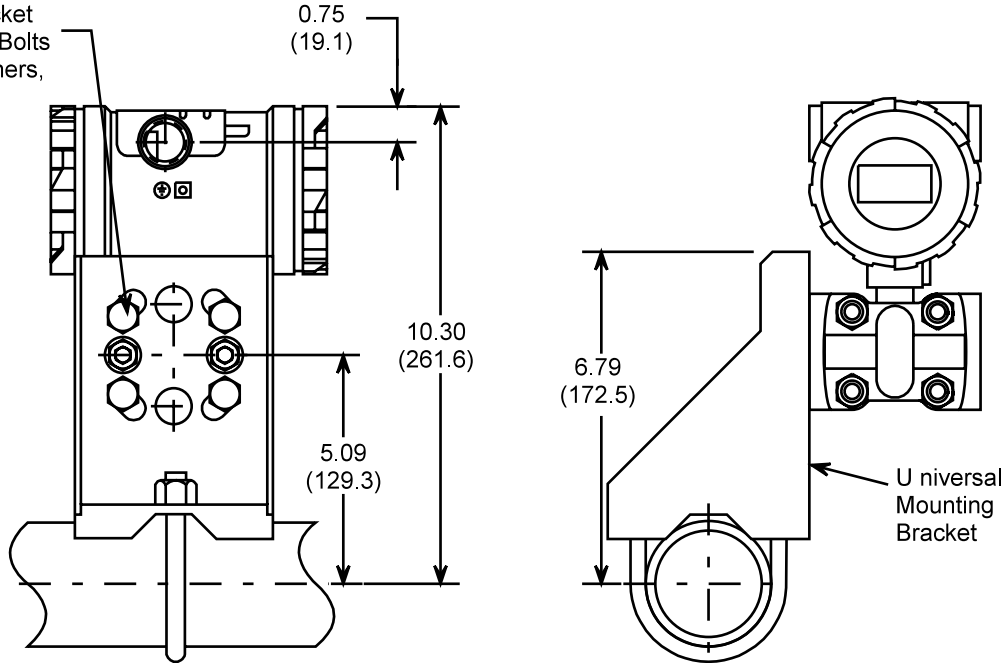

Dimensions are in inches (millimeters).

Model 345D and Models 345A and 345G with Tantalum Diaphragms

INSTALLATION DRAWINGS

Mount to Bracket with 7/16"-20 Bolts and Lockwashers, 4 places

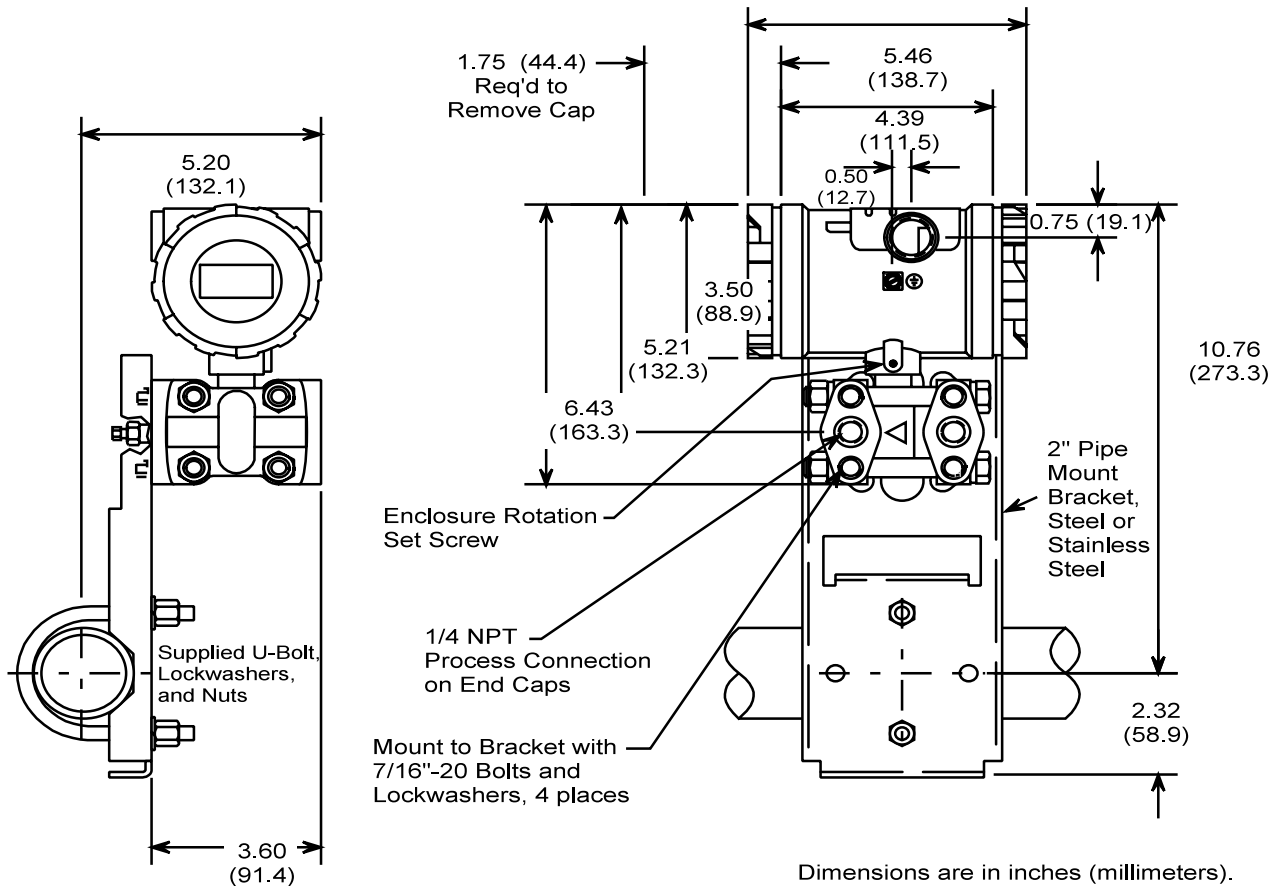
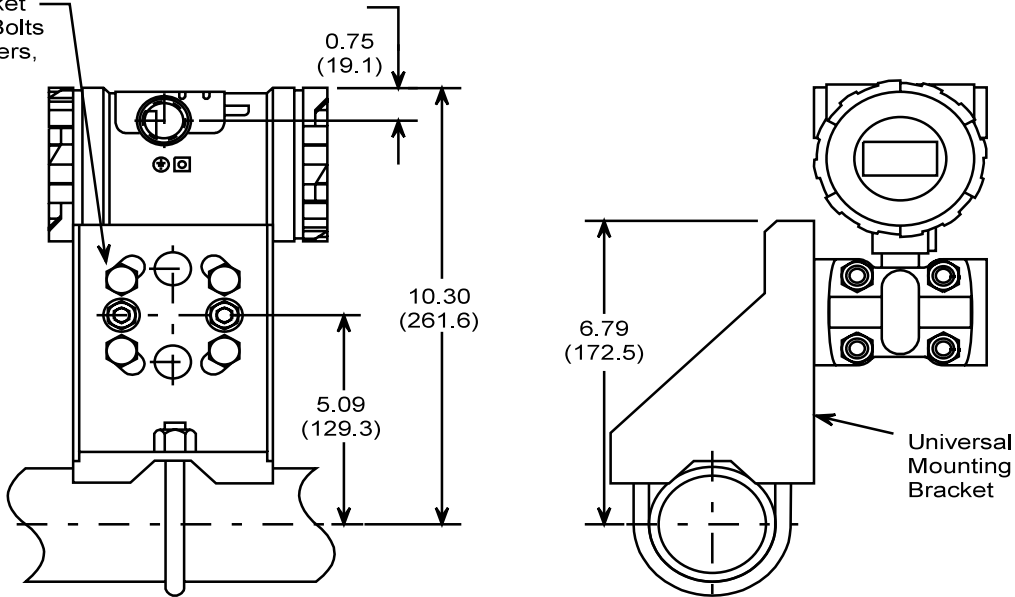

Dimensions are in inches (millimeters).

Models 345A and 345G

Model 345F Flange Mounted Transmitter

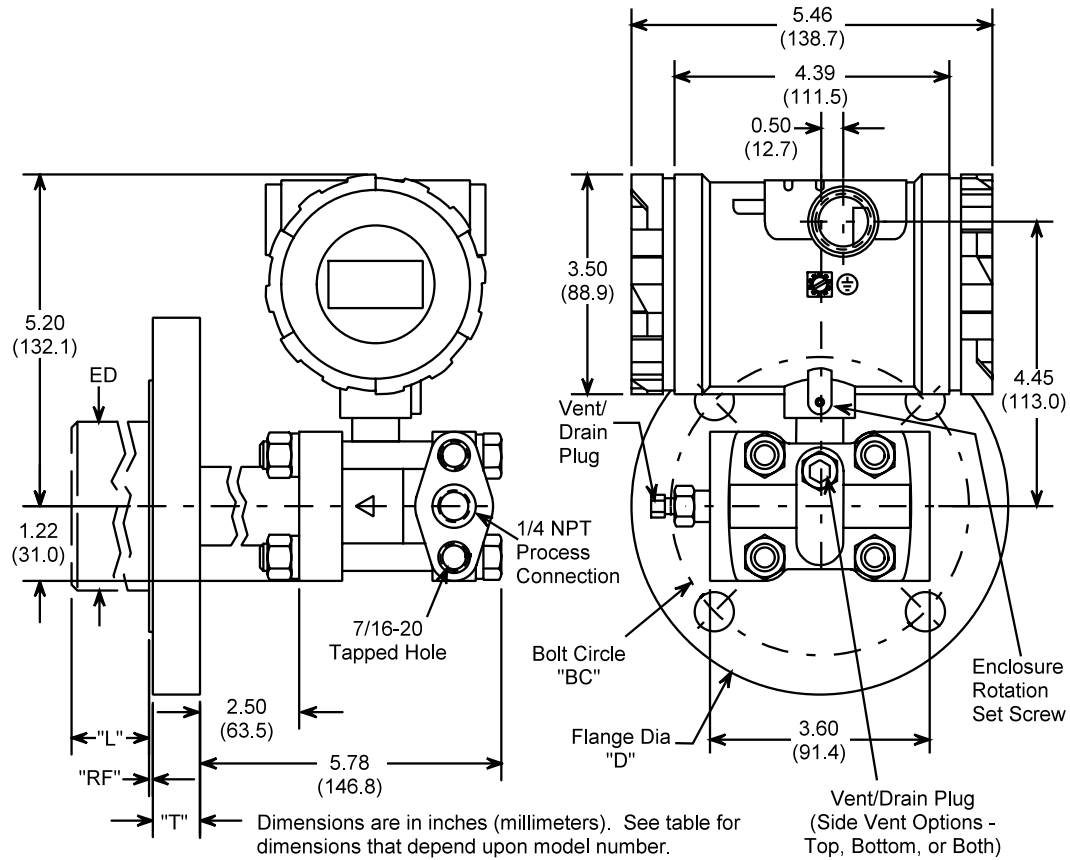

Flange and Extension Dimensions

Flange Dimensions

SIZE	DIM "D"	DIM "BC"	DIM "T"	DIM "RF"	BOLT DIA.	BOLT NO.	FLANGE PER	DIM "ED"
2"-150#	6.00 (152.40)	4.75 (120.65)	0.75 (19.05)		5/8	4		1.95 (49.53)
2"-300#	6.50 (165.10)	5.00 (127.00)	0.88 (22.23)		5/8	8		1.95 (49.53)
3"-150#	7.50 (190.50)	6.00 (152.40)	0.94 (23.81)	0.06 (1.58)	5/8	4		2.81 (71.37)
3"-300#	8.25 (209.55)	6.625 (168.28)	1.13 (28.58)		3/4	8	ANSI B16.5	2.81 (71.37)
4"-150#	9.00 (228.60)	7.50 (190.50)	0.94 (23.81)		5/8	8		3.70 (93.98)
4"-300#	10.00 (254.00)	7.875 (200.03)	1.25 (31.75)		3/4	8		3.70 (93.98)
50MM-10/16 BAR	6.50 (165.00)	4.92 (125.00)	0.71 (18.00)		M16	4		
50MM-25/40 BAR	6.50 (165.00)	4.92 (125.00)	0.79 (20.00)		M16	4		
80MM-10/16 BAR	7.87 (200.00)	6.30 (160.00)	0.79 (20.00)	0.12 (3.00)	M16	8	DIN 2526	Consult
80MM-25/40 BAR	7.87 (200.00)	6.30 (160.00)	0.94 (24.00)		M16	8	TYPE C	MycroSENSOR
100MM-10/16 BAR	8.66 (220.00)	7.09 (180.00)	0.79 (20.00)		M16	8		
100MM-25/40 BAR	9.25 (235.00)	7.48 (190.00)	0.94 (24.00)		M20	8		

Extension Length

(Not available on 2" or 50mm flanges.)

DIM "L"	0 (0.00)	2.00 (50.80)	4.00 (101.60)	6.00 (152.40)